

# 2015 AMERICAN RIVER PARKWAY TRAIL & PARKS



## PUBLIC COMMENT DRAFT



# POLICY & SIGN MANUAL

## TABLE OF CONTENTS

1.0	INTRODUCTION .....	3
2.0	REGULATORY SIGNAGE .....	6
3.0	DIRECTIONAL SIGNAGE .....	19
4.0	WARNING / SAFETY SIGNAGE .....	24
5.0	INFORMATIONAL SIGNAGE .....	28
6.0	INSTALLATION SPECIFICATIONS .....	32

APPENDIX 'A' – NEEDS ANALYSIS REPORT (24 page document)

APPENDIX 'B' – PARKWAY STAKEHOLDERS (one page document)

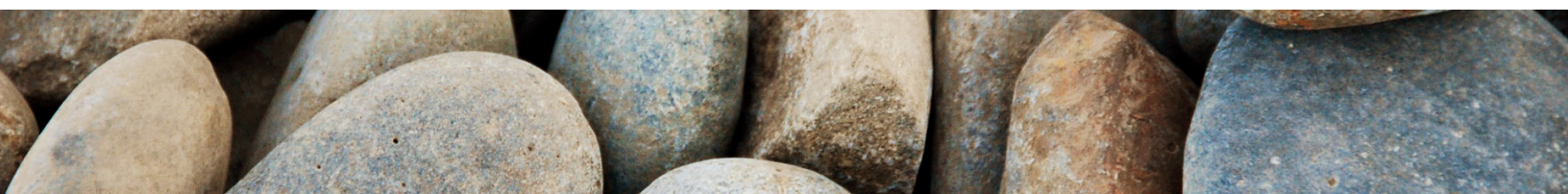



# Introduction

## Section 1.0

### A. BACKGROUND

In 2008, the American River Parkway (ARP) Plan recognized that “signing is an important communication tool to provide parkway users with directional assistance, to promote stewardship of the natural resources and to improve public safety by informing users about trail etiquette, permitted activities and use regulations”. The ARP Plan recommended the development of a signage plan to implement these objectives.

In the fall of 2013, County Regional Parks followed this recommendation by authorizing a project to develop a Plan for signing within the American River Parkway. The Signage Plan would include policies and standards for rules, regulations, safety, directional and other information.

During the first few months of 2014, consultants completed a Needs Analysis Report (Appendix ‘A’) which described existing conditions, and compared these conditions with state and federal sign standards, industry best practices for park signing, and recommendations of County staff and Parkway stakeholders (Appendix B).

Based on the findings and recommendations of the Needs Analysis, this draft Sign Policy/Manual was prepared and provides policy guidance for sign use, size, design, color, and locations.

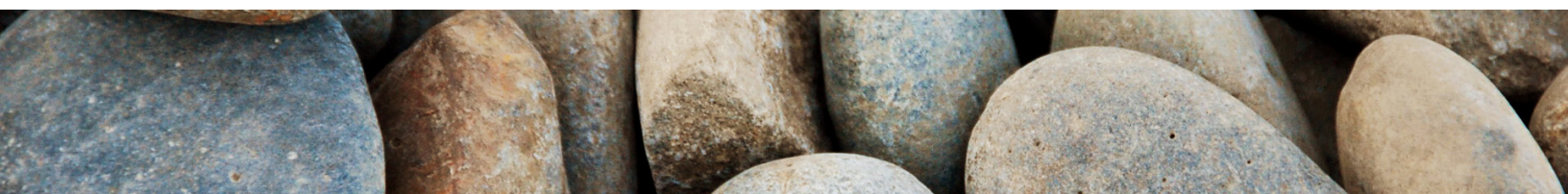

## SIGN POLICY/MANUAL

Signs are sometimes referred to as environmental graphics, and help people to locate and understand the services, rules, destinations and authorized activities within a park. At the same time, they also provide a coherent look and image for County Regional Parks. Signs provide a vital link to the public through visual communications.

Signs are inherently inharmonious with the natural setting. However, not having signs at all would make it difficult for a visitor to find facilities within a park, or to know the rules governing its use. Great care must be used in determining what it said, how it is said, and where it is said. Excessive and inconsistent signing adversely affects the beauty of a park and its use to the public, as well as detracting from the positive image of County Regional Parks.

An appropriate sign system takes into consideration effectiveness and quietness. An effective system is one that allows visitors to move safely and with a minimum of confusion to their destination and informs them of reasonable and necessary regulations.

A quiet system intrudes as little as possible on the natural beauty of the area and imposes to the smallest extent possible on the experience of the visitor. In order to achieve an effective and quiet sign system, uniformity is necessary in design, wording and sign/symbol placement.

Uniformity insures that the ARP visitor is given the same message in the same way. This reduces confusion and promotes safety. It allows the use of signs that are chosen for both maximum efficiency in delivering the necessary message and minimum intrusion on the natural setting. Uniform design also makes it possible to maintain a supply of standard signs, reducing delivery time on new and replacement signs. Finally, uniformity results in greater economy for the entire sign system, since special signs can be costly.

The intent of the Sign Policy/Manual is to establish guidelines and specifications for signing that will provide for an economical, quiet and efficient flow of necessary and useful information for visitors while intruding as little as possible on the natural beauty of the American River Parkway. The recommended sign policies and specifications within the Policy/Manual are consistent with the following policies of the American River Parkway Plan (page 127).

8.24 "Information and directional signage shall be designed to protect the visual qualities and aesthetic values of the Parkway. Signage shall use natural colors and materials to blend in with the surrounding environment, while being strategically located to be easily seen. Ground pavement stenciling is an effective means of signing with minimal Parkway impact".

8.25 "Informational and directional signage shall be placed at strategic trail access points that expressly state the permitted user groups, activities, and right-of-way hierarchy. Periodic directional signage shall be placed on the trail between access points."

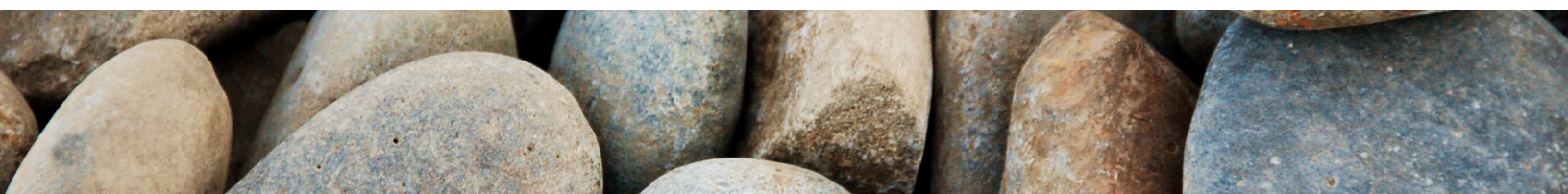

The Sign Policy/Manual is organized into four categories for way use and understanding. These categories are regulatory, directional, warning/safety, and informational signs. The manual provides a description of each sign category, and graphic samples of each sign with specifications for size, shape, color, location and use policy. Abbreviations for each category of signs are as follows:

Regulatory: REG

Directional: DIR

Warning/ safety: WAR

Informational: INF

Also included in the Sign Policy/Manual is a section detailing installation specifications.

The Sign Policy/Manual should be considered a “living” document that can be updated as signing needs change with changing conditions.



Aerial photograph of Discovery Park and downtown skyline.

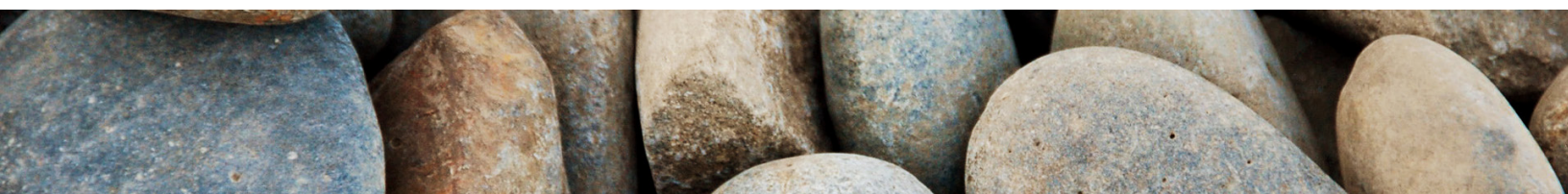



# Regulatory Signage

## Section 2.0

There are primarily two types of regulatory signs within the American River Parkway. The first type is rules and regulations for all park users such as hours of operation, dogs on leash, required fees and the like. The second type of signs relate to traffic control/safety for pedestrians, bicyclists, and persons driving vehicles. Bicycle trail signs may be a smaller version of the same signs that regulate motor vehicle traffic.

### GENERAL REGULATION SIGNS

General rules are those contained within the Uniform Park Ordinance that apply to all park facilities. To maximize effectiveness, signs are limited to rules concerning the activities that are most commonly troublesome in terms of park operations, such as animals, alcohol, and motor vehicle regulations. To be enforceable, these rules should be posted in such a manner that visitors have a reasonable opportunity to be aware of them. General rules signs contain too much information to be read from moving vehicles and should never be posted on roadways.

### INDIVIDUAL RULES SIGNS

Individual rule signs contain only one regulation and are designed for installation in areas where a particular activity has proved troublesome. Before any installation, it should be determined that nothing can be done to eliminate the hazard or situation, thus making the sign necessary. The number of rule and warning signs should be limited to those necessary to communicate a clear message. Individual rule signs should remain in place only as long as the problem exists.

### TRAFFIC CONTROL

The purpose of traffic control signs is to help insure roadway and bicycle trail safety by providing for the orderly and predictable movement of all bicycle and vehicular traffic. To be effective, a traffic control sign should meet five basic requirements.



They are:

Fulfill a need;

Command attention;

Convey a clear, simple meaning;

Command respect of road and paved trail users;

Give adequate time for proper response;

The warning and regulation of moving traffic on roadways; and,

Informing visitors of areas where vehicle use is limited or prohibited.

## WARNING AND REGULATION OF MOVING TRAFFIC

The warning and regulation of motorized vehicles and bicycles with signs provide the visitor with instructions for a safe and enjoyable visit. For example, a speed limit sign instructs the visitor with information needed to operate a vehicle or bicycle in a safe manner.

When it is determined that a sign is the best solution to a traffic problem, it is important to select the sign most suited to do the job. Care must be taken to avoid placing more signs than are necessary or signs that are too restrictive. To make a proper choice of signs it must be assumed that given reasonable requests or information, the average motorist/cyclist will respond in a reasonable manner.

Because of the specialized nature of some traffic related problems, it is possible that no standard sign deals with a particular problem. In such a case, it would be necessary to design a sign unique to the situation. These one-of-a-kind signs, however, should relate in design to the total traffic signing system and should be accomplished by the application of accepted traffic signing practices.

Once the proper sign message has been determined, the final decision regarding sign location requires consideration of the sign's relationship to the immediate environment. Several points should be considered. First, the sign should be located so that its special relationship to the hazard optimizes its effectiveness. Second, the sign should be placed so that it does not lose effectiveness through competition with other sign information. Where possible, traffic signs should be located a minimum of 50 feet from any other sign. The sign should be placed where it does not lose its effectiveness through competition with other objects, natural or artificial, which will block it or which are more likely to draw the visitor's attention. The details of sign location, such as angle to the roadway and height above the roadway, should conform to state standards and recommendations of the Sacramento County Department of Transportation.

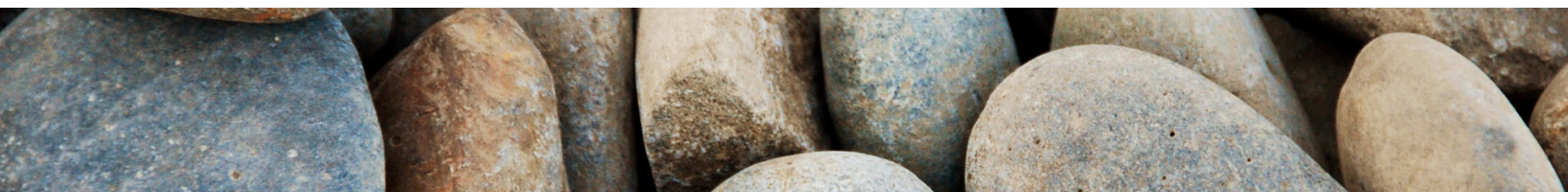

## PARKING AND RESTRICTED AREAS

Signs in this category inform visitors of areas where vehicle access is prohibited or is limited. As in the case of signs that regulate moving traffic, over-signing should be avoided by considering each sign installation in terms of its need.

### REGULATORY SIGNS



REG – 1 WELCOME SIGN

SIZE: 36" X 24", Aluminum

POLICY: Use to introduce uses for the park, and regulations that must be abided by.

LOCATION: Install on entrance kiosk at or near major entrances and access points.

COLOR: White on brown



REG – 2 SPEED LIMIT 15 MPH

SIZE: 24" X 18", Aluminum

POLICY: Use to give notice of a bicycle or vehicle speed limit (maximum on the trail is 15 mph).

LOCATION: Install in the standard position for use on roadways and along the Jedediah Smith National Recreation Trail at the beginning of the speed zone. When the speed zone is longer than one mile, intermediate signs may be posted at approximate one-mile intervals. Locate the sign no closer than 50 feet from any other sign.

COLOR: Black on white



REG – 3 BICYCLE STOP

SIZE: 18" X 18", Aluminum

POLICY: Use at intersections of trails and roadways where the bicycles are required to stop.

LOCATION: Install in the standard position on the right side of the bicycle trail in such a manner that a clear view is afforded.

COLOR: Reflective red





REG – 4 DO NOT ENTER

SIZE: 18" Diameter, Polyplate

POLICY: Use at the exit end of a one-way road or ramp to inform motorists that vehicle entrance is prohibited.

LOCATION: Install in the standard position for use on roadways near the exit end of a one-way ramp or road. It may be placed on either the right or left hand side and always in the head-on position to a wrong way movement.

COLOR: White lettering on red symbols



REG –5 BICYCLE YIELD

SIZE: 18" Sides, Polyplate, Reflective

POLICY: Use at intersections of trails and roadways where it is desirable to assign right of way to motor vehicle traffic but where a Stop Sign is unduly restrictive. Do not install this sign where sight distance is so limited a near stop is necessary before entering the intersection.

LOCATION: Install in the standard position on the right side of the bicycle trail in such a manner that a clear view is afforded.

COLOR: Reflective red



REG – 6 NO CAMPING

SIZE: 12" X 12", Polyplate

POLICY: Use to inform visitors that camping is not permissible.

LOCATION: Install as needed around parkway.

COLOR: White symbol and on brown background.



REG – 7 DOGS ON 6' LEASH

SIZE: 18" X 12", Polyplate

POLICY: Use to inform park users of the county leash regulation.

LOCATION: Install as needed

COLOR: White on brown background



REG -8 NO FIRES

SIZE: 12" X 12", Polyplate

POLICY: Use to inform park users of areas where fires are prohibited.

LOCATION: Install near parking areas, at trailheads and other locations as needed to prevent users from building fires.

COLOR: White on brown with red stripe



REG - 9 MULTI-USE TRAIL

SIZE: 12" X 12", Polyplate

POLICY: Use to identify or to indicate the direction to a bicycle trail.

LOCATION: Install in the standard position for use beside either roads or pathways or fence mount at trailheads as needed.

COLOR: White on brown background



REG - 10 NO PARKING

SIZE: 18" X 12", Polyplate

POLICY: Use to inform park users of areas where vehicle parking is prohibited.

LOCATION: Install in the standard position on the right in locations where parking is not allowed.

COLOR: Red lettering on white background.



REG - 11 NO STOPPING ANYTIME

SIZE: 18" X 12", Polyplate

POLICY: Use to inform park motorists of a no stopping zone at a specific location.

LOCATION: Install in the standard position for use on the right as needed to prevent parking and stopping.

COLOR: Red lettering on white background.

REG – 12 DISABLED PARKING ONLY

SIZE: 18" X 12", Polyplate

POLICY: Use to designate disabled persons vehicle parking only.

LOCATION: If one or two stalls are to be reserved for disabled persons, use one sign centered at the head of the stalls of the reserved area; if more than two stalls are to be reserved, install signs at each end of the reserved area stall. Utilize VAN lettering to indicate stalls designed to accommodate disabled vans.

COLOR: White on blue.



REG – 14 TRAIL DIRECTIONAL ARROW

SIZE: 18" X 18", Polyplate

POLICY: Use to warn bicyclists of trail direction at changes that may not be apparent to the bicyclists.

LOCATION: Install as needed on bicycle trails in the standard positions.

COLOR: Black symbol on yellow background

REG – 16 EQUESTRIAN CROSSING

SIZE: 12" X 12", Polyplate

POLICY: Use to inform park users of areas where equestrian trails cross other trails or roadways.

LOCATION: Install in the standard position for use at locations where equestrians may be encountered by pedestrians, bikes or motorists.

COLOR: Black symbol/lettering on yellow background or white on brown



REG – 17 BICYCLE CROSSING

SIZE: 18" X 18", Polyplate

POLICY: Use to inform park users of areas where bicycle trails cross other trails or roadways.

LOCATION: Install in the standard position for use at locations where bicyclists may be encountered by pedestrians, drivers, or equestrians.

COLOR: Black symbol/lettering on yellow background

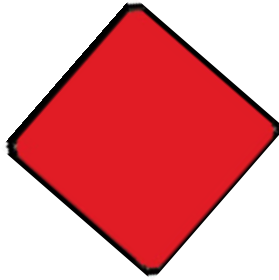

**REG – 18 TRAIL END RED REFLECTOR**

**SIZE:** 24" x 24", Aluminum reflective

**POLICY:** Use to warn trail users and motorists of end of trail or road, in combination with barricade or gates.

**LOCATION:** Attach to barricade or gate or on low posts that form end of trail/road barricade. Place directly in line of sight of path of travel.

**COLOR:** Highly reflective red.



**REG – 19 END**

**SIZE:** 24" X 24", Polyplate

**POLICY:** Use at a cul-de-sac or on a park gate that when not closed is normally approached at a speed of 25 mph or more.

**LOCATION:** Install in a head-on position.

**COLOR:** Black lettering on a yellow background.



**REG – 20 NO MOTORCYCLES**

**SIZE:** 18" Diameter, Polyplate

**POLICY:** Use to identify a road or area where motorcycle access is prohibited but only when motorcycle access is an actual problem. Do not use this sign to post a road already posted with a No Motor Vehicles sign.

**LOCATION:** Install as needed on trails or roads.

**COLOR:** Black image on white background with red stripe diagonally through circle.



**REG – 21 PARK ENTRANCE FEE**

**SIZE:** 18" X 12", Polyplate

**POLICY:** Use to inform visitors of park entrance fee and self payment process.

**LOCATION:** Install at all vehicle entrances near parking areas, in plain sight.

**COLOR:** Combination of two signs, one with red lettering on white background and one with white lettering on brown background.



**REG – 22 PARK HOURS**

**SIZE:** 18" X 24", Polyplate

**POLICY:** Use to inform park users of the hours of operation of the park.

**LOCATION:** Install at all vehicular, and pedestrian and bicycle park entrances at eye level in plain sight, on fences, gates, posts and/or poles.

**COLOR:** White lettering on brown background.



**REG – 23 ROAD CLOSED**

**SIZE:** 24" X 24", Polyplate

**POLICY:** Use to inform users of closed roads that are normally or seasonally open, or permanently closed.

**LOCATION:** Install sign on gate or on fence / barrier.

**COLOR:** Black lettering on yellow background.



**REG – 24 YIELD TO**

**SIZE:** 18" Sides, Polyplate

**POLICY:** Use to inform park users of the priority of right-of-way on multi-purpose trails.

**LOCATION:** Install in the standard position on the right hand side of trail near trailheads, at parking lots and selected major intersections of multiple trail types.

**COLOR:** Black and white lettering and graphics on yellow background.



**REG – 25 BICYCLE YIELD**

**SIZE:** 24" X 24", Polyplate, Reflective

**POLICY:** Use to instruct drivers to yield to bicyclists.

**LOCATION:** Install in the standard position on the right side of the bicycle trail in such a manner that a clear view is afforded in both directions on the roadway carrying motor vehicle traffic.

**COLOR:** Black lettering with red yield symbol and standard bike symbol in black on a yellow background.





The green Heron (*Butorides Virescens*) is a small heron of North and Central America. It was long considered conspecific with its sister species the Striated Heron (*Butorides Striata*), and together they were called "Green-Backed Heron". Birds of the nominate subspecies (no matter which taxonomic arrangement is preferred) are extremely rare vagrants to Western Europe; individuals from the Pacific coast of North America may similarly stray as far as Hawaii.

The Green Heron is relatively small; adult body length is about 44 cm (17 in). The neck is often pulled in tight against the body. Adults have a glossy, greenish-black cap, a greenish back and wings that are grey-black grading into green or blue, a chestnut neck with a white line down the front, grey underparts and short yellow legs. The bill is dark with a long, sharp point. Female adults tend to be smaller than males, and have duller and lighter plumage, particularly in the breeding season. Juveniles are duller, with the head sides, neck and underparts streaked brown and white, tan-splotched back and wing coverts, and greenish-yellow legs and bill. Hatchlings are covered in down feathers, light grey above, and white on the belly.

The Green Heron's call is a loud and sudden kyow; it also makes a series of more subdued kuk calls. During courtship, the male gives a raah-rah call with wide-open bill, makes noisy wingbeats and whoom-whoom-whoom calls in flight, and sometimes calls roo-roo to the female before landing again.



REG – 26 AUTHORIZED VEHICLES ONLY

SIZE: 24" X 18", Polyplate

POLICY: Use to warn motorists that access to areas is prohibited except for authorized vehicles only.

LOCATION: Install at gates, bollards, fence or driveway where access is not allowed to the public without special permission.

COLOR: Black lettering on white background



REG – 27 GLASS BEVERAGE CONTAINERS PROHIBITED

SIZE: 18" Diameter, Polyplate

POLICY: Use to alert park users of the County's policy prohibiting the use of glass beverage containers.

LOCATION: Install near picnic areas, restrooms or other use with glass container use and litter issues.

COLOR: Black symbol on white background with red stripe



REG – 28 NO DUMPING

SIZE: 24" X 18", Polyplate

POLICY: Utilize to inform the public of the prohibition and fines incurred for dumping waste material on park lands.

LOCATION: Install as needed, dumping problems exist.

COLOR: Black lettering on a white background



REG – 29 NO ALCOHOL

SIZE: 18" X 24", Polyplate

POLICY: Use to inform park users of the County's alcohol policy for regional parks.

LOCATION: Install near picnic areas, restrooms or other high traffic areas.

COLOR: White lettering on brown background





REG – 30 NO STOPPING BUS ONLY

SIZE: 24" X 18", Polyplate

POLICY: Use to inform motorists where only busses are allowed to stop.

LOCATION: Install as needed in parking lots or bus only loading zones.

COLOR: Red lettering on white background



REG – 31 FIRE LANE NO PARKING

SIZE: 24" X 18", Polyplate

POLICY: Use to warn motorists of a fire equipment access area where parking is restricted and towing is imminent.

LOCATION: Install as needed per fire prevention access identified zones.

COLOR: Red lettering on a white background



REG – 32 MOTORCYCLE PARKING ONLY

SIZE: 24" X 18", Polyplate

POLICY: Use to inform motorists of parking areas restricted to motorcycles.

LOCATION: Install as needed in parking lots.

COLOR: Red lettering and on white background

JOGGERS & WALKERS  
USE LEFT SHOULDER  
WHEN POSSIBLE

SKATEBOARDS  
PROHIBITED

SPEED LIMIT  
15 MPH

REG – 33 TRAIL REGULATION STENCILING

SIZE: 4" Text ("Speed limit" - 6", Numerical value of speed limit - 9")

POLICY: Use to alert trail users of major rules governing trail usage and speed limit.

LOCATION: Approximately each ½ mile and at major trail starting points in both directions.

COLOR: White lettering painted onto asphaltic concrete

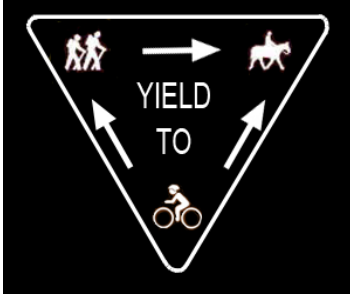

REG – 34 YIELD TO STENCILING

SIZE: 6" Text, overall stencil size - 24"x24"x24"

POLICY: Use to alert trail users of rules for yielding to other users.

LOCATION: Approximately each mile and at major trail starting points in both directions, centered in each lane of traffic.

COLOR: White lettering and graphics painted onto asphaltic concrete



REG – 35 DO NOT ENTER HABITAT AREA

SIZE: 18" X 12"

POLICY: Use to keep visitors out of restricted sensitive habitat areas.

LOCATION: As needed for permanent restricted areas.

COLOR: White on brown background

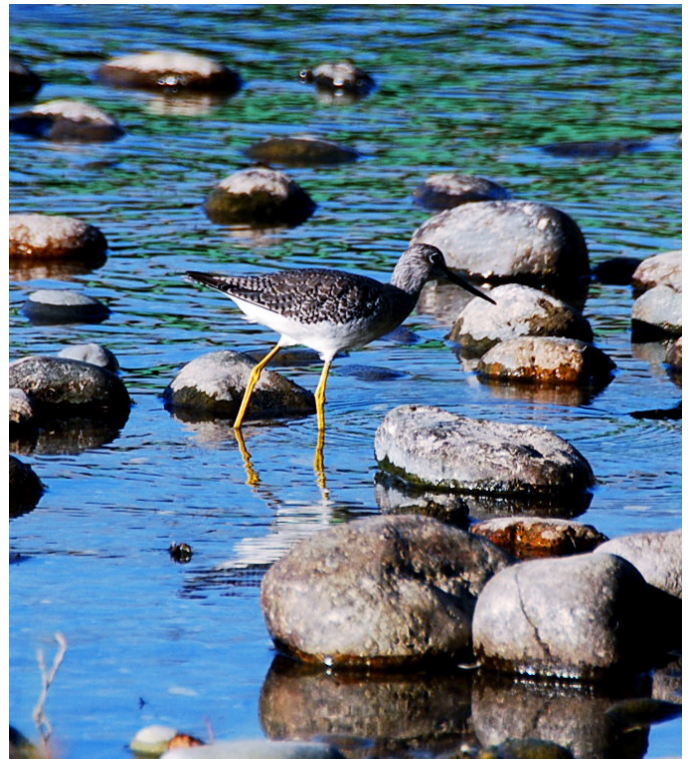



# Directional Signage

## Section 3.0



Directional signs direct visitors to, and identify facilities within the American River Parkway such as picnic areas, restrooms, parking and trails. Within the ARP there are two separate systems of facility identification signing. The first is a general identification system that directs visitors to, and identifies all facilities except trails. The second system identifies and guides trail users over paved and unpaved trails. The two systems are discussed separately.

### **GENERAL IDENTIFICATION**

General identification signing is divided into two functions: 1. Guiding visitors to various facilities. 2. Identifying the facilities so visitors know when they have reached their destination. The signs comprising these two functions provide a flow of information beginning at the entrance area and ending at the various facilities.

Two types of guide signs are used to assist visitors in finding facilities. The first is signs designed for use at major road intersections and used to direct visitors to certain destinations, such as overflow parking (pg. 17). The second type of guide sign is a smaller unit such as the picnic sign (pg. 18). This type is usually used as a single destination sign.

Most of the signs in the facility identification category use a symbol in place of words to deliver a message. These signs have the advantage of having less visual impact on the environment than a lettered sign of the same size and can be read from a greater distance and by persons who may not understand the English language. In most applications, these symbols alone are sufficient to convey the necessary message. Through the use of this unified system of guide and identification signs, park visitors should experience a minimum of difficulty in making their way from park entrances to their desired destinations.

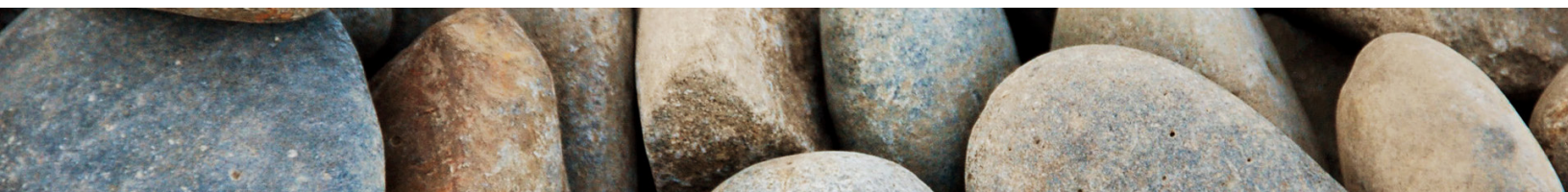

## DIRECTIONAL SIGNS



DIR – 1 OVERFLOW PARKING

SIZE: 18" X 24" Polyplate

POLICY: Use to indicate a specific location (may include distance).

LOCATION: At or near vehicular entrances and primary parking areas.

COLOR: White on brown



DIR – 2 WILDLIFE VIEWING

SIZE: 12" X 12" Polyplate

POLICY: Use to indicate direction to a specific location (may include distance).

LOCATION: At or near areas designed to support wildlife viewing.

COLOR: White on brown



DIR – 3 BIKE TRAIL INTERSECTION OR START

SIZE: 12" X 12" Polyplate

POLICY: Use to indicate direction to bike trail destination (may include distance).

LOCATION: At or near bike trail access points.

COLOR: White on brown



DIR – 4 HIKING AND EQUESTRIAN TRAIL

SIZE: 18" X 12" Polyplate

POLICY: Use to indicate multipurpose equestrian/hiking trail entrance.

LOCATION: At or near trail access points

COLOR: White on brown

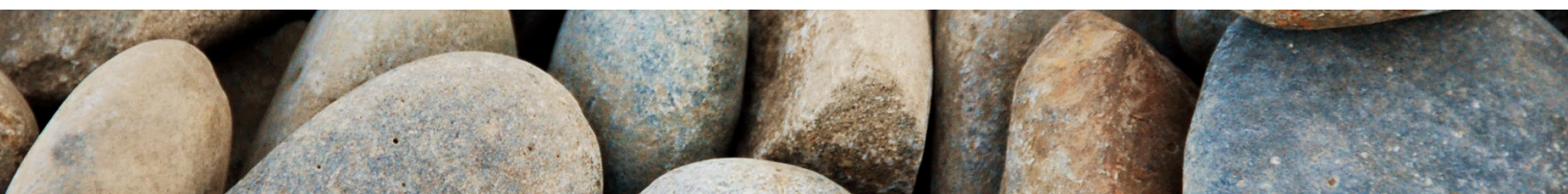



DIR – 5 HANDICAP ACCESSIBLE ENTRANCE

SIZE: 18" X 12" Polyplate

POLICY: Use to indicate direction or identify accessible facilities.

LOCATION: At or near accessible points on roads or pathways.

COLOR: White on blue



DIR – 6 MILE MARKERS

SIZE: 12" X 12" Polyplate

POLICY: Use to indicate location on trails and/or distance traveled.

LOCATION: Along the trail, beginning at trail head.

COLOR: White on brown



DIR – 7 PICNIC AREA

SIZE: 12" X 12" Polyplate

POLICY: Use to indicate direction to or identify a picnic area.

LOCATION: At or near picnic areas.

COLOR: White on brown



DIR – 8 NO OUTLET

SIZE: 18" X 18" Polyplate

POLICY: Use to indicate access limitations of a specific location.

LOCATION: At or near areas without an outlet.

COLOR: black on yellow



DIR – 9 BOAT LAUNCH

SIZE: 12" X 12" Polyplate

POLICY: Use to indicate a specific location where boat launch is allowed (may include directional arrow).

LOCATION: At boat launch areas.

COLOR: White on brown



DIR – 11 HORSE TRAILER PARKING

SIZE: 18" X 18" Polyplate

POLICY: Use to indicate direction or identify areas where horse trailers may be parked.

LOCATION: At or near areas designed to support horse trailers.

COLOR: Black on white



DIR – 12 DIRECTIONAL SIGN

SIZE: 18" X 24" Polyplate

POLICY: Signs used to indicate general directions to specific locations (may include distance).

LOCATION: At the entrance to the park, near trail heads or major access areas.

COLOR: White on brown





DIR – 13 RIVER ACCESS

SIZE: 18" X 24" Polyplate

POLICY: Use to indicate where the river is accessible to pedestrians.

LOCATION: At entrances to trails to the river.

COLOR: White on brown



**\*\*\*REVISION TO THIS SIGN IS PENDING\*\*\***

DIR – 14 YOU ARE HERE

SIZE: 24" X 36" Polyplate

POLICY: Maps used to indicate direction to specific locations (may include distance), including current location.

LOCATION: At the entrance to the park, near trail heads or major access areas.

COLOR: Black on white

DIR – 15 CROSS STREET NAME STENCILS

SIZE: 4" Text

POLICY: Use to inform park users of the street names as they approach intersections.

LOCATION: 50' to 100' prior to street crossing in each direction so it can be read. Preferably not under bridges or deeply shaded areas unless unavoidable.

COLOR: White paint on asphaltic concrete pavement





# Warning and Safety Signage

## Section 4.0



Warning/safety signs inform visitors of County rules governing parkland use or warn them of possible hazards. Of all County signs, those in the warning category should be the most obvious to park visitors. By thoughtful and selective use of these signs, it will be possible to notify visitors of risks and hazards, thereby providing both a safe and enjoyable experience.

Warning signs should remain in place only as long as the problem that they were meant to remedy exists. If the problem is seasonal or short term, the sign should be considered temporary, and left in place only during the appropriate period.



Photo By: Robert Couse-Baker



## WARNINGS/SAFETY SIGNS



WAR – 1 CROSS TRAFFIC AHEAD

SIZE: 24" X 24", Aluminum, Reflective

POLICY: Use to advise users of approaching cross traffic intersection.

LOCATION: Install in the standard position on right side of trail between 100' and 50' from an intersection with vehicles crossing the trail path of travel.

COLOR: Black lettering on reflective yellow



WAR – 2 REDUCE SPEED

SIZE: 18" X 18", Polyplate

POLICY: Use to remind bicycle users to slow down when they are about to pass on multipurpose trails.

LOCATIONS: Install on multipurpose trails only. Install in the standard position for use beside either roads or pathways or fence mount at trailheads or other appropriate locations as needed.

COLOR: Black lettering on yellow background



WAR – 3 PEDESTRIAN CROSSING

SIZE: 18" X 24", Aluminum, Reflective

POLICY: Use to warn bicyclists that a trail or walkway pedestrian crosswalk is in close proximity.

LOCATION: Install 100 to 50 feet in advance of a pedestrian crosswalk, and to be used in combination with painted white crosswalk pattern on the bike trail pavement.

COLOR: Black on reflective yellow





WAR – 4 BRIDGE HEIGHT

SIZE: 8" X 18" Polyplate

POLICY: Use to inform drivers the clearance of the bridge.

LOCATION: Install on bridge at the entrance on each side, where easily visible.

COLOR: Black on reflective yellow



WAR – 5 NO JUMPING OR DIVING FROM BRIDGE

SIZE: 8" X 18" Polyplate

POLICY: Use to ensure bridge users remain safely on the bridge.

LOCATION: Install on bridge along pedestrian walk way.

COLOR: Black on white background



WAR – 6 STOP AHEAD

SIZE: 24" X 24" Polyplate

POLICY: Use to inform drivers of a stop approaching.

LOCATION: Install in advance of a Stop sign by 150 feet for trails and by 400 feet for roads.

COLOR: Black lettering on reflective yellow



**\*\*\*NEW SIGN IS PENDING\*\*\***

WAR – 7 RIVER DANGERS

SIZE: 24" X 18" Polyplate

POLICY: Use to inform visitors of the potential dangers of the river.

LOCATION: Install near river, and/or river access points.

COLOR: Black on reflective yellow



**WAR – 8 FOR YOUR SAFETY**

SIZE: 18" X 12" Polyplate

POLICY: Use to inform visitors of precautions they can take to ensure a safer environment

LOCATION: Install near trail heads

COLOR: White on brown

PEDESTRIANS: 1. Use left shoulder  
2. Facing Oncoming bicyclists  
3. Single file when overtaking other users

BICYCLE RIDERS: 1. Stay in your lane

2. Single file when overtaking other users

All users yield to Equestrians



**WAR – 9 BUMP**

SIZE: 18" X 18", Polyplate

POLICY: Use to inform bicyclists of approaching potentially hazardous bump in the road, either temporary or permanent.

LOCATION: Install in the standard position 100 feet ahead of hazard on the right side in each direction of hazard, as necessary.

COLOR: Black lettering on yellow background.



**WAR – 10 CAUTION BLIND HILL**

SIZE: 18" X 18", Polyplate

POLICY: Use to inform bicyclists of curves and vertical elevation changes that results in blind approaches where reducing speed and extra caution is needed.

LOCATION: Install in the standard position on the right side of trail as needed.

COLOR: Black lettering on yellow background.



**WAR – 11 BLIND CURVE**

SIZE: 18" X 12", Aluminum, Reflective

POLICY: Use to inform park users of a blind curve when driving.

LOCATION: Install at locations where the curve of the road prevents drivers from being able to see beyond.

COLOR: Black on reflective yellow



# Informational Signage

## Section 5.0

Informational signs provide park-specific information and/or requests that the visitor to act or not act in specific ways, for example "please take valuables with you" or "call out before passing". They do not carry the force of law, but rather ask the visitors cooperation in some aspect of park operations. These signs should be used carefully, and only when the assistance is meaningful and necessary. If placed where assistance is not actually needed or the request is overly restrictive, visitors will lose respect for the signs and disregard further requests for cooperation.



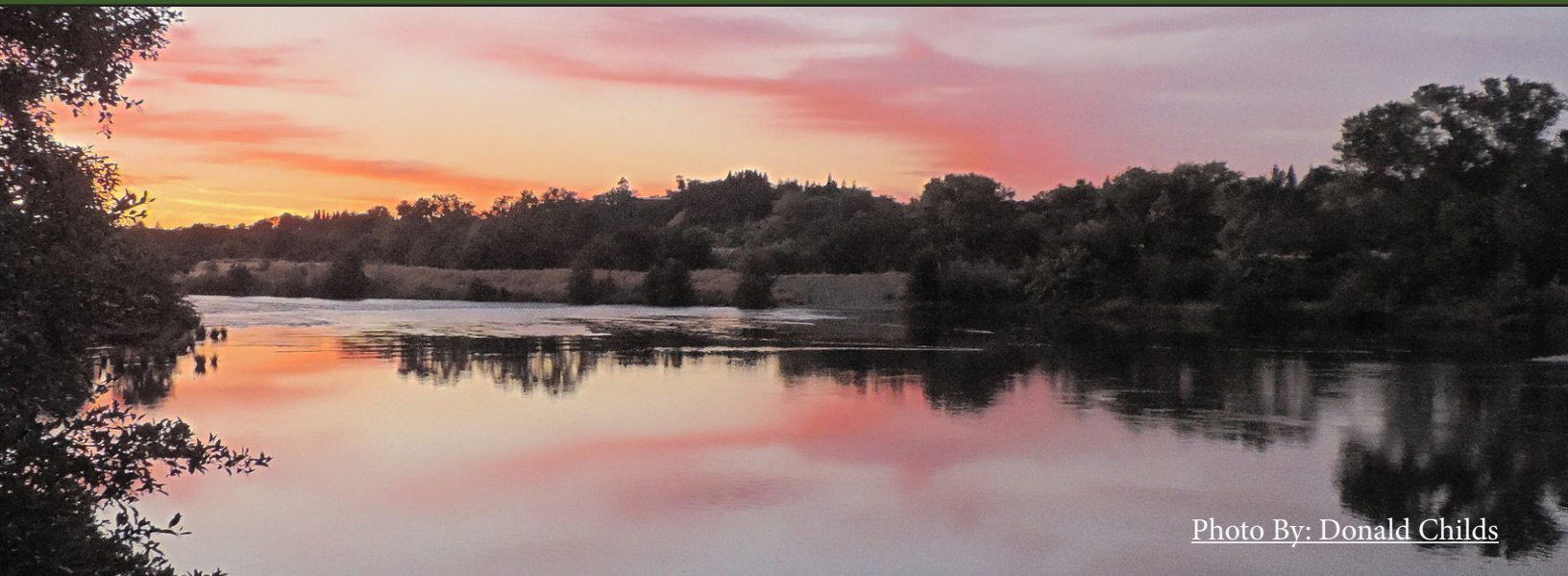

Photo By: Donald Childs

## **INFORMATIONAL SIGNS**

INF – 1 RULES

SIZE: 36" X 24", Polyplate

POLICY: Use to inform park users of rules, regulations and courtesies expected.

LOCATION: Install at parking lots, pedestrian entrances, or other major gathering areas. Do not place near roadway; sign not meant to be read from moving vehicles.

COLOR: White lettering on brown background

**RULES AND COURTESY**  
**SHARE THE ROAD**

**BICYCLES**

- Speed limit is 15 mph
- Helmets are required for persons under 18 and recommended for all others
- Avoid accidents by calling out "On Your Left" when passing another cyclist
- Be alert for pedestrians on trails
- Stay on pavement

**PEDESTRIANS**

- Use left side of trail, facing on-coming bicyclists
- When able, walk on left side of shoulder

**WHEEL CHAIRS**

- Use right side of trail

**DOGS**

- Dogs required to be on a leash not more than 6' long
- Should be walked on the outside shoulder of the trail

**ASSISTANCE**

- For emergencies call 911
- For information call (916) 875 - PARK (7275)

**RULES AND COURTESY**  
**SHARE THE ROAD**

**BICYCLES**

- Speed limit is 15 MPH
- Helmets are recommended for all users (under 18 is required by law)
- Ride single file when approaching and passing any other users on the trail
- Stay on pavement

**PEDESTRIANS**

- Use left side of trail facing on-coming bicyclists
- Use single file when approaching and passing any other users

**WHEEL CHAIRS**

- Use right side of trail

**DOGS**

- Dogs required to be on a leash not more than 6' long
- Should be walked on the outside shoulder of the trail

**ASSISTANCE**

- For emergencies call 911
- For information call (916) 875 - PARK (7275)

**TWO SIGN VARIATIONS - FEEDBACK REQUESTED**

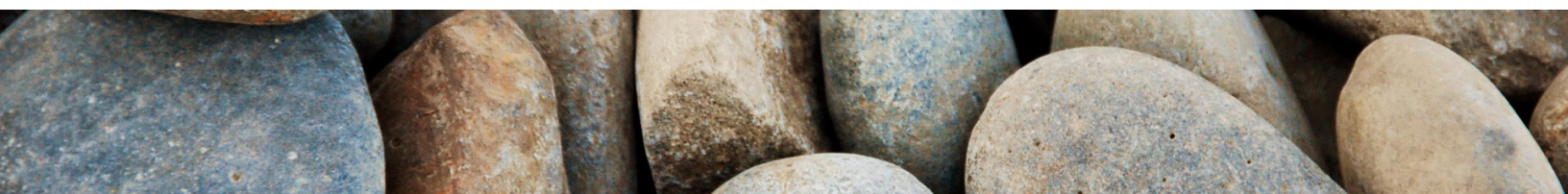



INF – 1 ANNUAL PASS SIGN

SIZE: 24" X 18", Polyplate

POLICY: Use to inform park users of the convenience of purchasing an annual pass.

LOCATION: Install near payment kiosks.

COLOR: White on brown



INF – 2 LOCK YOUR CAR

SIZE: 24" X 18", Polyplate

POLICY: Use to inform park users to lock their cars, and take all valuables they can with them to avoid stolen items.

LOCATION: Install near parking lots.

COLOR: White on brown



INF – 3 PLEASE CLEAN UP AFTER DOG

SIZE: 18" X 12", Polyplate

POLICY: Use to inform park users that dogs must be on a leash at all times.

LOCATION: Install near trails, parking lots, etc.

COLOR: White on brown



INF – 4 STAY ON TRAIL

SIZE: 18" X 12", Polyplate

POLICY: Use to inform park users of the need to stay on the trail.

LOCATION: Install near trail heads.

COLOR: White on brown

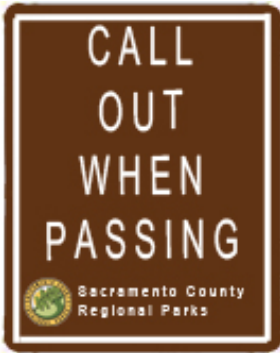

INF – 5 PASSING CALL-OUT

SIZE: 18" X 12", Polyplate

POLICY: Use to remind bicycle users to warn other trail users when they are about to pass on multipurpose trails.

LOCATIONS: Install on multipurpose trails only. Install in the standard position for use beside either roads or pathways or fence mount at trailheads or other appropriate locations as needed.

COLOR: White lettering on brown background



# Installation Specifications

## Section 6.0

Free standing signs shall be installed with the bottom of the signs a minimum of five feet above adjacent pavement surfaces, and 5 feet ideally, but at least 2 feet from the outside edge of shoulder, and/or decomposed granite in most cases. Where no shoulder exists, measure from edge of pavement (E.P.). Exceptions to these mountings may be made to avoid sight restrictions or other undesirable conditions.

Signs of different types are not ordinarily mounted on the same posts. Exceptions to this are supplementary signs.

Regulatory and Warning Signs

Wayfinding Signs

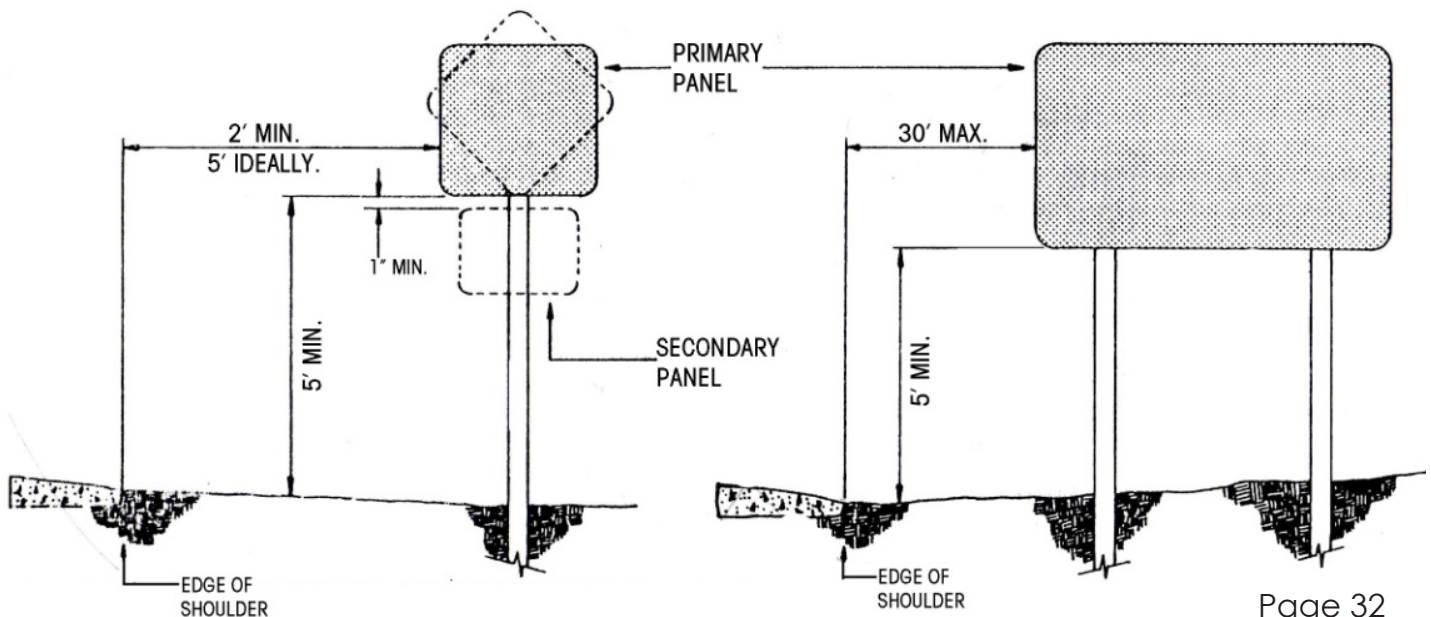



Clearheart 4"x 4" redwood posts shall be used for mounting. When possible, place signs in protected locations.

Posts shall be mounted in the ground via concrete footings with  $\frac{1}{2}$ " slope away from post for drainage, at least 18" deep, and 10" in diameter.

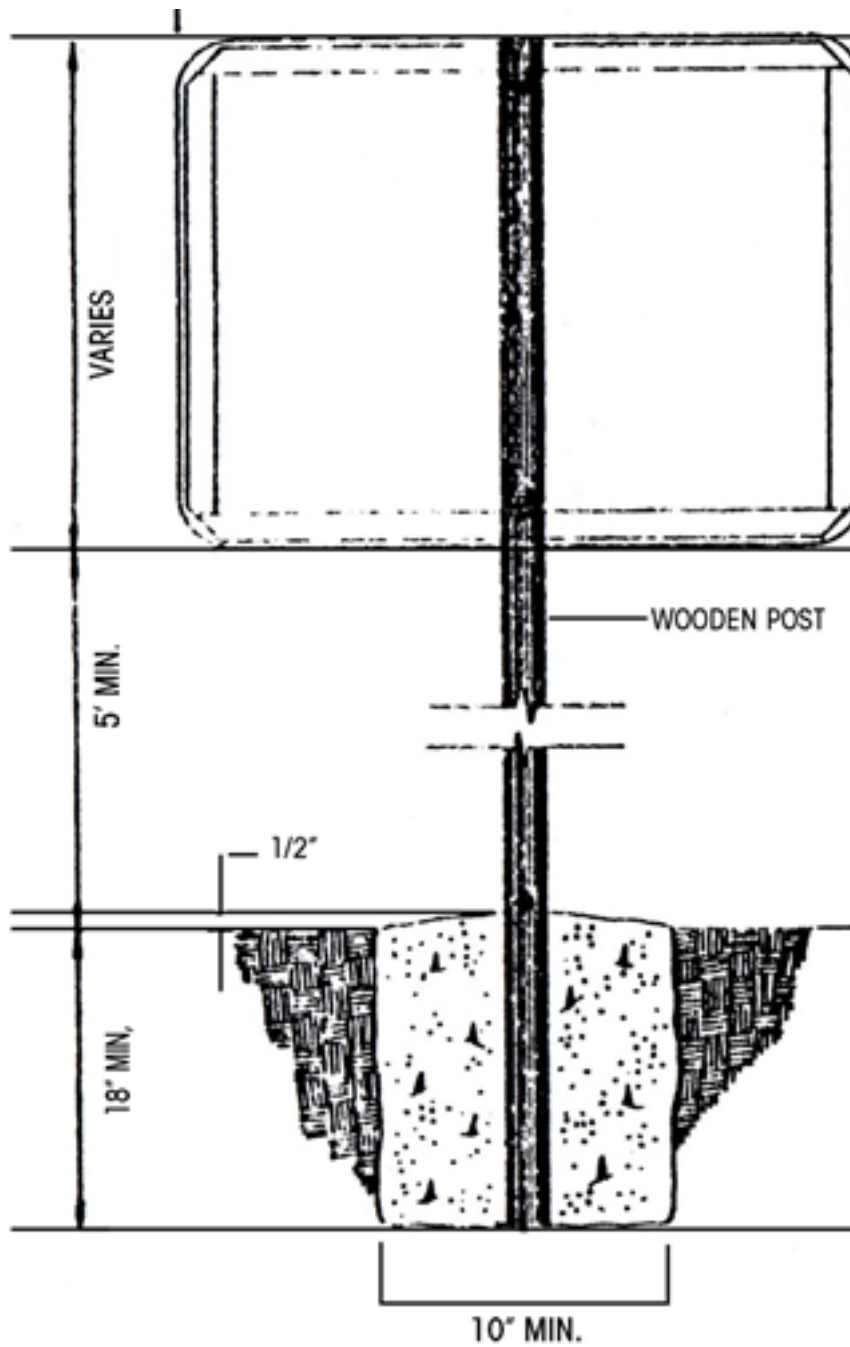

# Appendix 'B'

Special thank you's are extended for the participation, oversight and creativity of the following individuals who served as stakeholder representatives in the creation of the American River Parkway Signage Manual and Needs Analysis.

The following persons served in this capacity:

1. John Havicon, El Cid Nieto and Jeff Leatherman (Regional Parks)
2. Patrick Carpenter (County DOT)
3. Paul Height (County Risk Management)
4. Rick Heyer (County Legal Counsel)
5. Dianna Pogetto and Scott Wolcott (ARP Foundation)
6. Warren Truitt (SARA)
7. Ginger Enrico (Sun River HOA)
8. Rich Hanna (running community)
9. Guy Galante (nature appreciation/photographer)
10. Sue Fossum (equestrian groups)
11. Charlie Willard (kayak/special events)
12. Jim Brown (bicycle community)
13. Jay Abbott (Sac Valley Conservancy)
14. Jim Whelan (bicycle community)

